

**WARNING**

• Obtain, read and carefully service instructions when installing parts. A loose, worn, or damaged parts may cause injury to the rider.  
We strongly recommend that only genuine Shimano replacement parts be used.

**SERVICE INSTRUCTIONS** SI-6C80B

**ST-6510 ST-5500-CA** Shimano Total Integration

Before use, read these instructions carefully, and follow them for correct use.

**Shimano Total Integration Features**

The Shimano Total Integration ULTEGRA / 105 series features a dual action control lever which actuates the brakes like a conventional brake lever, and shifts the gears when moved inward toward the center line of the bicycle. Gear shifting is now possible without ever taking your hands off the brake hoods or drops.

Operation of the levers related to gear shifting should be made only when the front chainwheel is turning.

In order to realize the best performance, we recommend that the following combination be used.

Series	ULTEGRA	
Shifting lever	ST-6510	
Outer casing	SP40	
Gears	18	27
Front derailleur	FD-6500	FD-6503
Front chainwheel	FC-6500	FC-6503
Bottom bracket	BB-6500	
Rear derailleur	RD-6500	RD-6500GS
Freehub	FH-6500	
Cassette sprocket	CS-6500	
Chain	CN-HG92 / CN-7700	
Bottom bracket cable guide	SM-SP17	

Series	SHIMANO 105	
Shifting lever	ST-5500-CA	
Outer casing	SIS SP40	
Gears	18	27
Front derailleur	FD-5500	FD-5503
Front chainwheel	FC-5501	FC-5504
Bottom bracket	BB-5500	
Rear derailleur	RD-5500	RD-5500GS
Freehub	FH-5500	
Cassette sprocket	CS-HG70-9	
Chain	CN-HG72	
Bottom bracket cable guide	SM-SP17	

**Note**

- For smooth operation, always be sure to use the specified outer casing and the bottom bracket cable guide.
- Grease the inner cable and the inside of the outer casing before use to ensure that they slide properly.
- Because the high cable resistance of a frame with internal cable routing would impair the SIS function, this type of frame should not be used.
- The end of the outer casing which has the aluminum cap should be at the derailleur side.

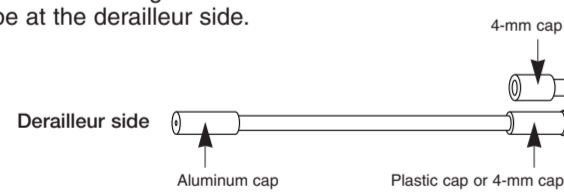

• The cycle computers shown in the table below are compatible.

Meter unit	SC-6500/SC-6501
Bracket sensor unit	SM-6500 <sup>1)</sup> /SM-6500-RS/SM-6501

<sup>1)</sup>The bracket cover must be replaced.  
(ST-6510 → Replace with bracket cover for ST-6501.)  
(ST-5500-CA → Replace with ST-5500-C.)

- Read the service instructions for the cycle computer also.
- For maximum performance we highly recommend Shimano lubricants and maintenance products.
- For any questions regarding methods of installation, adjustment, maintenance or operation, please contact a professional bicycle dealer.

**SHIMANO**  
SHIMANO AMERICAN CORPORATION  
One Holland Irvine CA 92618 U.S.A. Phone 949-951-5003  
SHIMANO EUROPA  
Industrieweg 24 NL-8071 CT Nunspeet Holland Phone 31-341-27222  
SHIMANO INC.  
77 Omitsu-cho 3-cho Sakai Osaka 590-8577 Japan Phone 0722-23-3243  
Please note: specifications are subject to change for improvement without notice. (English)  
© Aug. 2000 by Shimano Inc. XBC SZK Printed in Japan.

**Operation**

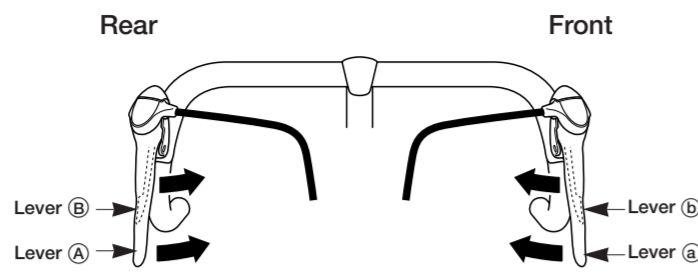

Lever (A) : Shifts from smaller to larger rear sprocket.  
Lever (B) : Shifts from larger to smaller rear sprocket.  
Lever (a) : Shifts from smaller to larger chainring.  
Lever (b) : Shifts from larger to smaller chainring.

All levers return to the starting position when released.

**Operation of rear derailleur lever**

- Lever (A) : Shifts from smaller to larger rear sprocket. Lever (A) has a click stop at positions ①, ②, and ③.

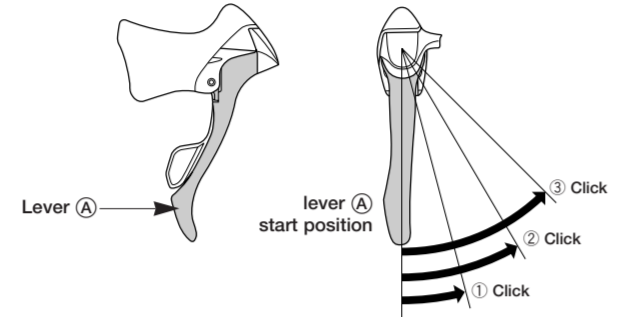

- ① : Shifts one sprocket  
E.x. : from 3rd to 4th

- ② : Quick-shifts two sprockets  
E.x. : from 3rd to 5th

- ③ : Quick-shifts three sprockets  
E.x. : from 3rd to 6th

- Lever (B) : Shifts from larger to smaller rear sprocket. Press lever (B) once to shift from a larger to one smaller sprocket.

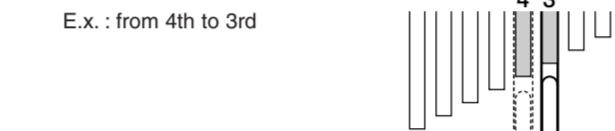
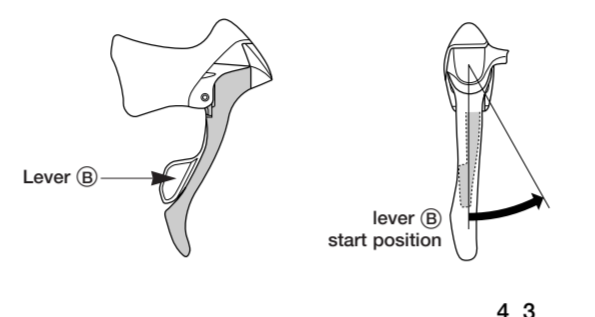

**Caution on operation**

Lever (B) will also move when lever (A) is operated, but be careful not to apply pressure to lever (B). Similarly be careful not to press lever (A) when operating lever (B). Gears will not shift when both levers are pressed simultaneously.

Be sure to read these service instructions in conjunction with the service instructions for the RD-6500 / RD-6500GS / RD-5500 / RD-5500GS before use.

**Operation of front derailleur levers (FD-6500 / FD-5500)**

- Lever (a) : Shifts from smaller to larger front chainring.

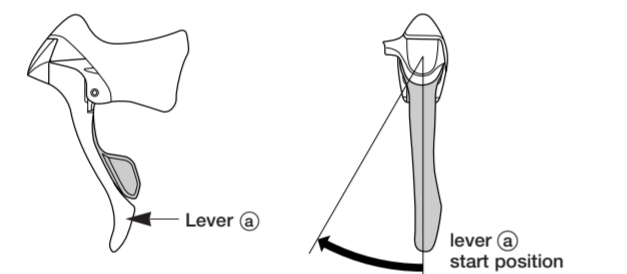

If operation of lever (a) does not complete the chainring shift stroke, operate lever (a) again for the distance (X) to complete that part of the lever stroke (X) which was short.



- Lever (b) : Shifts from largest chainring to intermediate chainring.

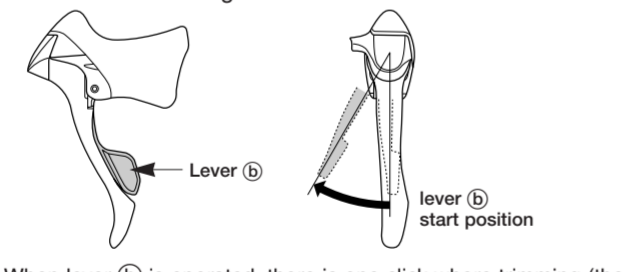

When lever (b) is operated, there is one click where trimming (the noise prevention mechanism) engages, and a second stronger click when the gear shift stroke is completed. After trimming, the next push will complete the gear shift stroke to the smaller front chainring.

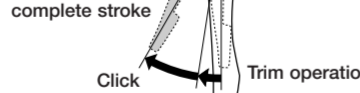

**Trimming (noise prevention operation)**

If the chain is on the large front chainwheel and the larger rear sprocket, the chain will rub in the front derailleur plate, producing a characteristic noise. When this happens, press lever (b) lightly (to the point where it clicks); this causes the front derailleur to move slightly towards the smaller chainwheel, thereby eliminating the noise.

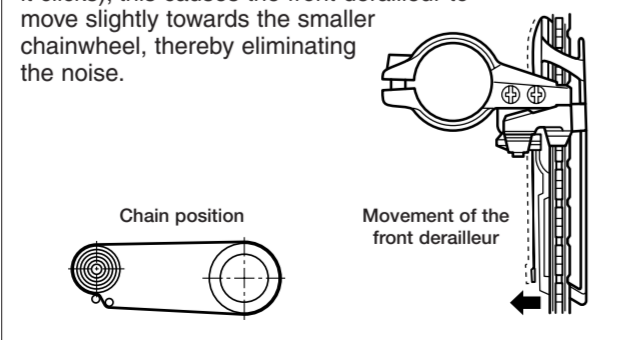

**Operation of front derailleur levers (FD-6503 / FD-5503)**

- Lever (a) : Shifts from smaller to larger front chainring.

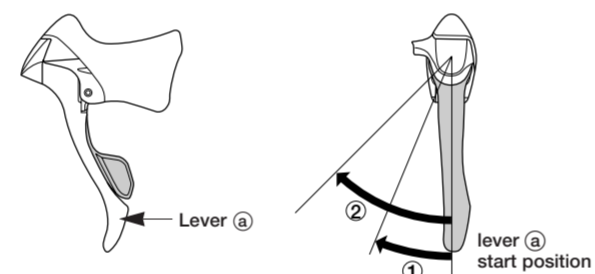

If operation of lever (a) does not complete the chainring shift stroke, operate lever (a) again for the distance (X) to complete that part of the lever stroke (X) which was short.

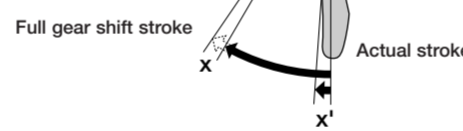

- Lever (b) : Shifts from largest chainring to intermediate chainring.

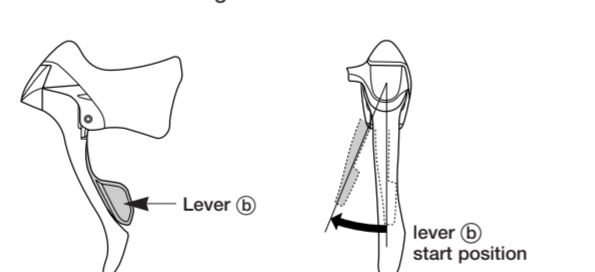

- Lever (b) : Shifts from intermediate chainring to smallest chainring.

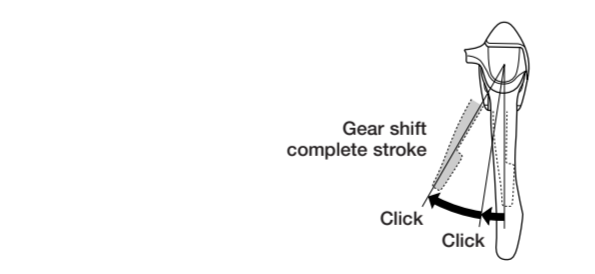

**Caution on operation (FD-6500/FD-6503/FD-5500/FD-5503)**

Lever (b) will also move when lever (a) is operated, but be careful not to apply pressure to lever (b). Similarly be careful not to press lever (a) when operating lever (b). Gears will not shift when both levers are pressed simultaneously.

Be sure to read these service instructions in conjunction with the service instructions for the FD-6500 / FD-6503 / FD-5500 / FD-5503 before use.

**Installation**

**Installation to the handlebar**

Secure the assembly with the installation nut on the outside of the bracket. Pull the bracket cover back and use a 5 mm Allen key to tighten the bolt.

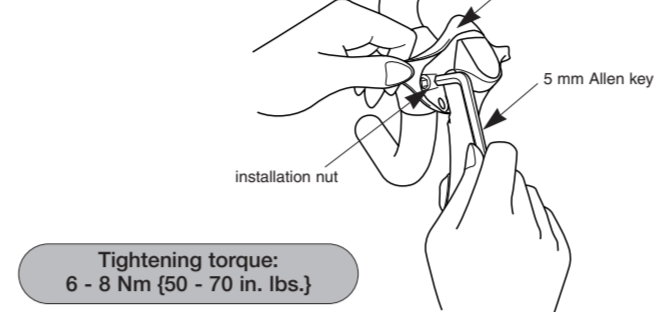

Tightening torque: 6 - 8 Nm (50 - 70 in. lbs.)

**Installation of the brake cable**

- Cable used
- Inner cable (stainless steel) .....  $\phi 1.6$  mm
- SLR outer casing .....  $\phi 5$  mm

Be sure to leave some excess cable, even if cutting it to the full length of the handlebars.

- 1. Tilt the lever in (as when shifting) to make it easier to pass the cable through the cable hook.

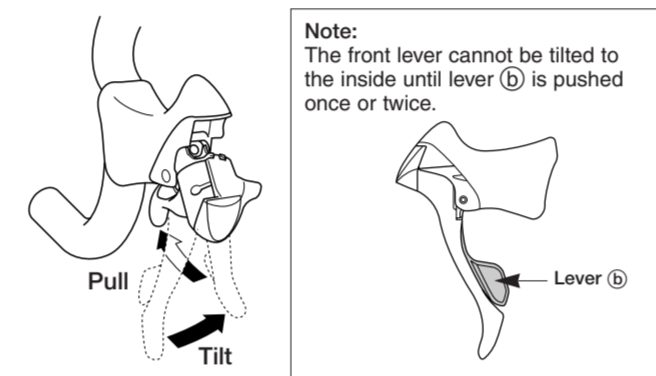

- 2. Pass the inner cable through.

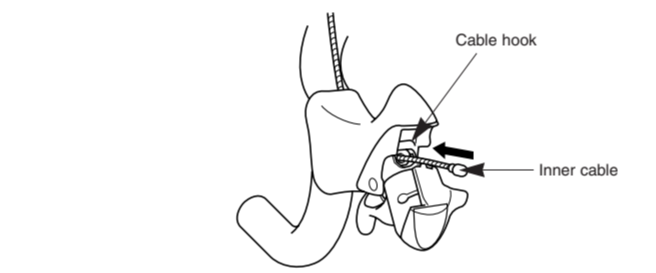

- 3. Fix the outer guide to the inner cable, and set the angled member in the bracket.

Note: Do not wipe the grease on the inner cable off. Also, be careful that the inner cable does not pick up dust and foreign matter.

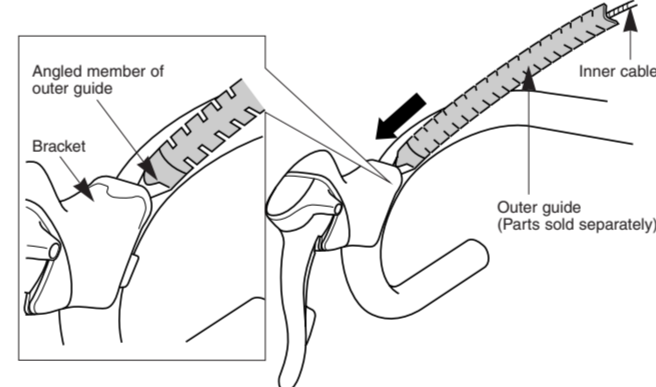

- 4. Set the outer casing on the inner cable, and in the bracket along the outer guide.

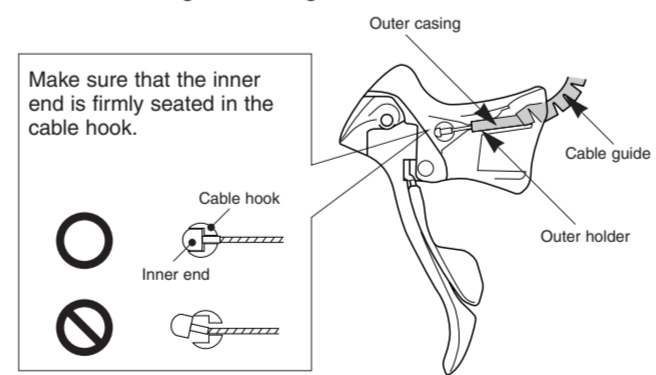

- 5. Bring the outer casing along the front of the handlebar and cover it with the outer guide. Now cut the outer guide to the length of the handlebar, and tape it temporarily in place.

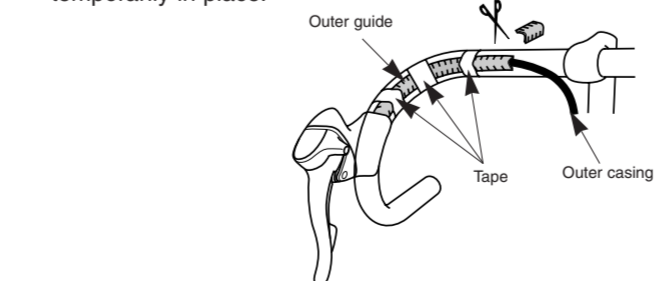

- 6. Finally, wrap the handlebar with the finish tape.

**Installing the shifting cable**

- Cable used
- Inner cable (stainless steel)  $\phi 1.2$  mm
- SP40 sealed outer casing (1)  $\phi 4$  mm
- SP40 outer casing (2)  $\phi 4$  mm

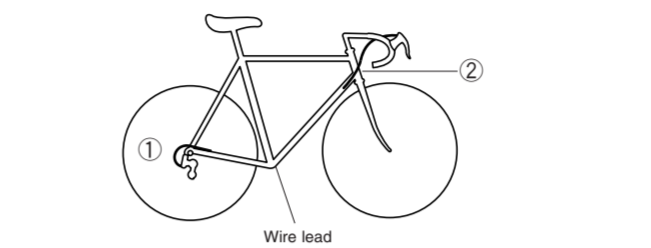

Inserting the inner cable  
Insert the inner cable into the outer casing from the end with the marking on it. Apply grease from the end with the marking in order to maintain cable operating efficiency.

Cutting the outer casing  
When cutting the outer casing, cut the opposite end to the end with the marking. After cutting the outer casing, make the end round so that the inside of the hole has a uniform diameter.

Attach the same outer end cap to the cut end of the outer casing.

- Rear lever  
Push lever (B) at least 8 times to make sure the mechanism is in top gear before installing.

Depress the brake lever, and then pass the inner cable through the cable hole.

If the cable hook does not align with the shifting cable hole, press lever (B) again until it does, and then install the cable.

Make sure that the inner end is firmly seated in the cable hook.

- Front lever  
Push lever (a) at least two - three times before installing.

Pull the brake lever (as when braking) to pass the inner cable through the shifting cable hole, and set it in the outer casing.

- Outer stopper  
1. Install the outer stopper to the down tube.

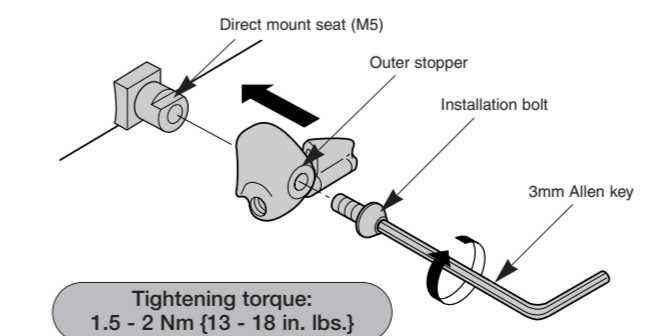

Install the outer stopper for the rear chainwheels with the handle in the default position.  
2. Pass the inner cable through, and set the outer casing. Be sure leave some excess in the outer casing, even if cutting it to the full length of the handlebars.

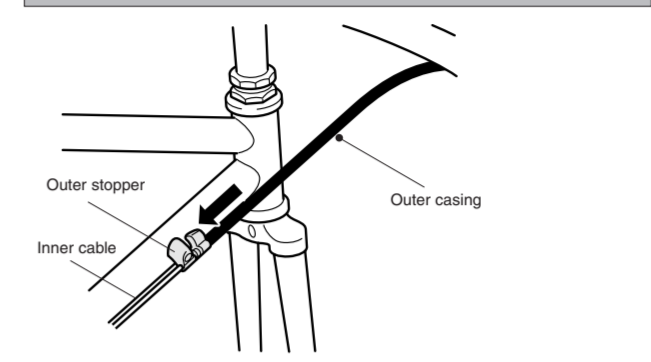

Confirm  
Make sure the outer casing is firmly seated in the outer stopper.

**Maintenance**

**Bracket and lever disassembly**

- 1. Remove the sensor cap, and use a 2 mm Allen key to remove the lever stud set screw on the bottom of the bracket.

- 2. Insert a 2.5 mm Allen key or similar tool into the lever stud hole, and tap it gently with a plastic mallet to push out the lever stud. When the lever stud comes out, the bracket body and lever body can be disassembled. After this, pull the sensor cable out from the bracket body.

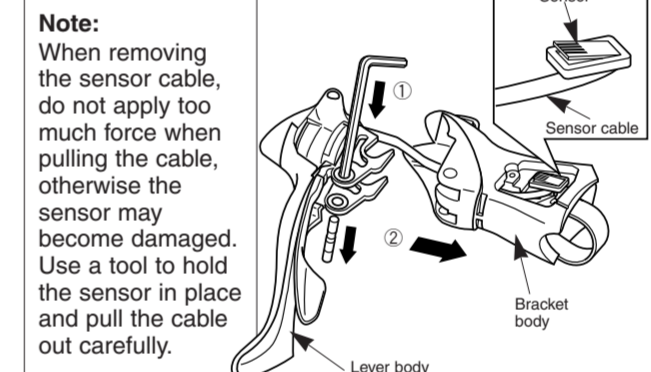

**Lever and bearing assembly disassembly**

- 1. Remove the cable hook.

- 2. Disassemble using the special tool and a 5 mm Allen key.

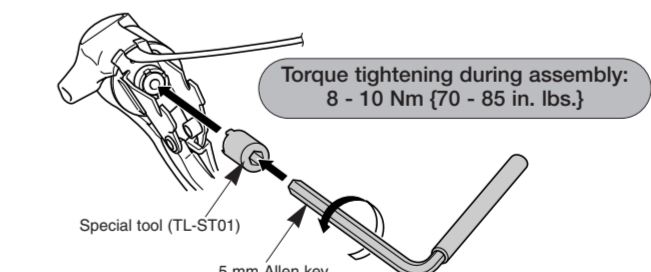

- 3. Disassemble as shown.

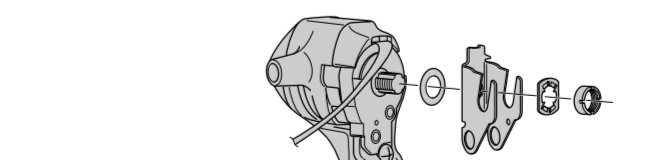

Do not disassemble any further as reassembly may not be possible.

- Be sure to regrease.

**Assembling the bracket and lever**

- 1. Put the cable hook in to the bearing member, and set the return spring.

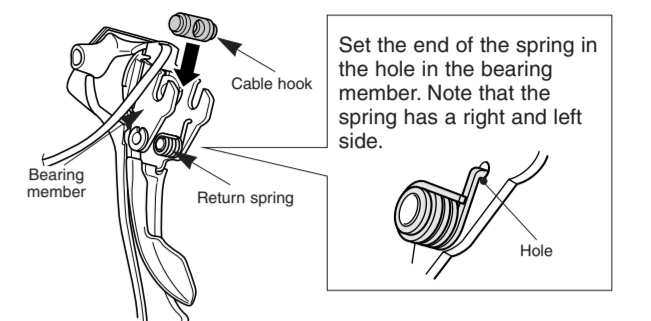

- 2. Set the special installation tool for the return spring.

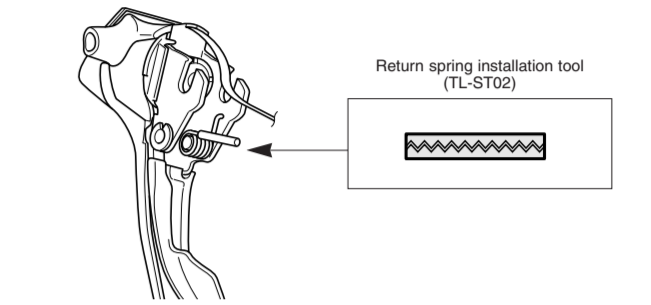

- 3. First insert the sensor cable into the bracket body, and then assemble the bracket body and lever body. Be careful that the end of the return spring does not protrude from the hole in the bearing member at this time.

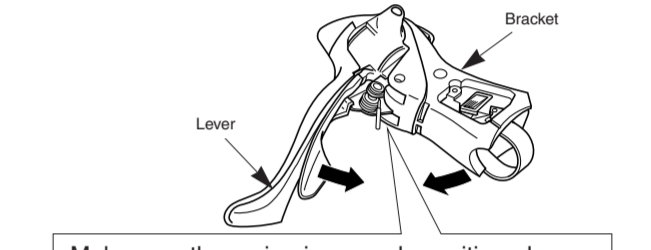

Make sure the spring is properly positioned.

- 4. Align the stud holes, and then press-fit the lever stud.

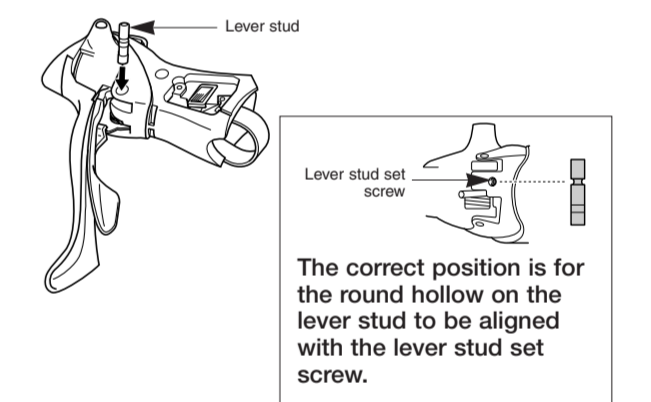

- 5. Remove the return spring installation tool with pliers.

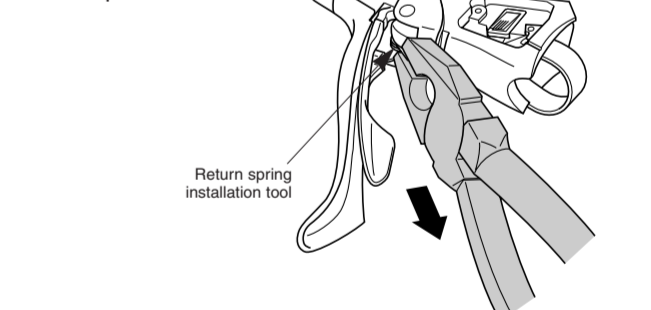

- 6. Tighten the lever stud set screw until it is even with the surface of the bracket. Lastly, install the sensor cap.

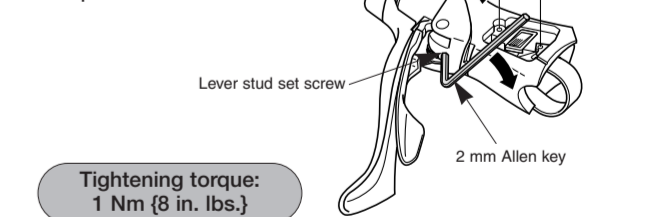

**Replacing the bracket cover**

The tabs on the bracket cover each fit to a matching slot on the bracket.

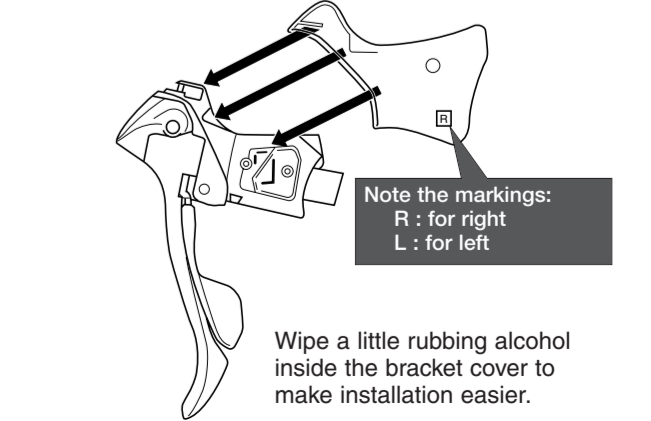

Note the markings: R : for right L : for left  
Wipe a little rubbing alcohol inside the bracket cover to make installation easier.